

EP Fuse

Normal blow

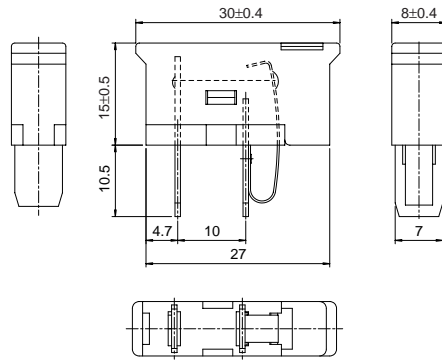
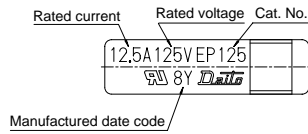

- Physical Size · Net Weight
8 × 30 × 25.5mm 4.7g
- Color
Dark Green
- Package
50Pcs/Box
- Applicable Fuseholders
EPH-4P

Carrying Capacity	Clearing Time
100%	135% within 1 hour 200% within 2 minutes

Cat. No.	Rated Current	Breaking Capacity	Typ. Resistance*1
EP80	8A	AC/DC 125V 200A	10mΩ
EP100	10A		9mΩ
EP125	12.5A		6mΩ
EP150	15A		5mΩ
EP200	20A		3mΩ

*1 : at 10% max. of rated current

Clearing Characteristics

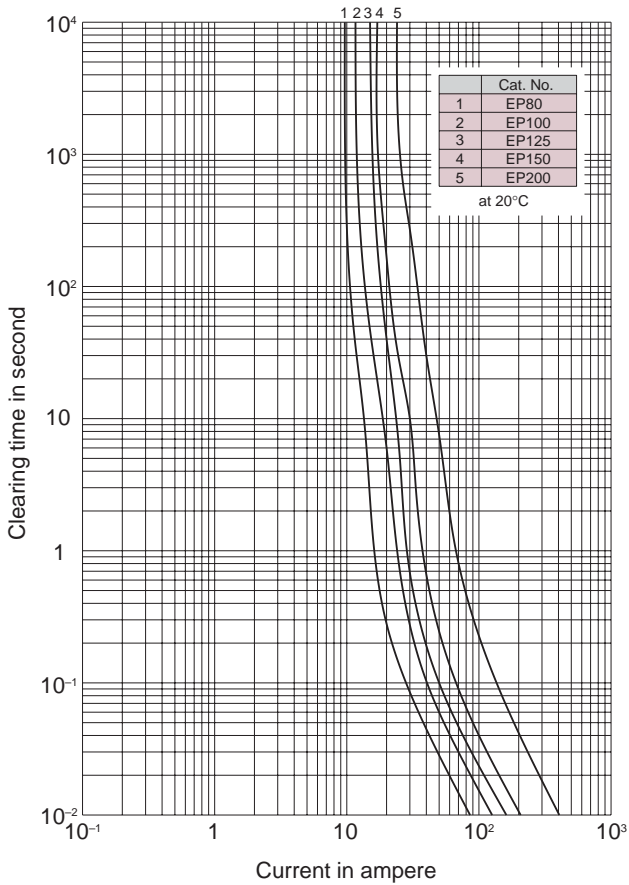

I²t Characteristics

